

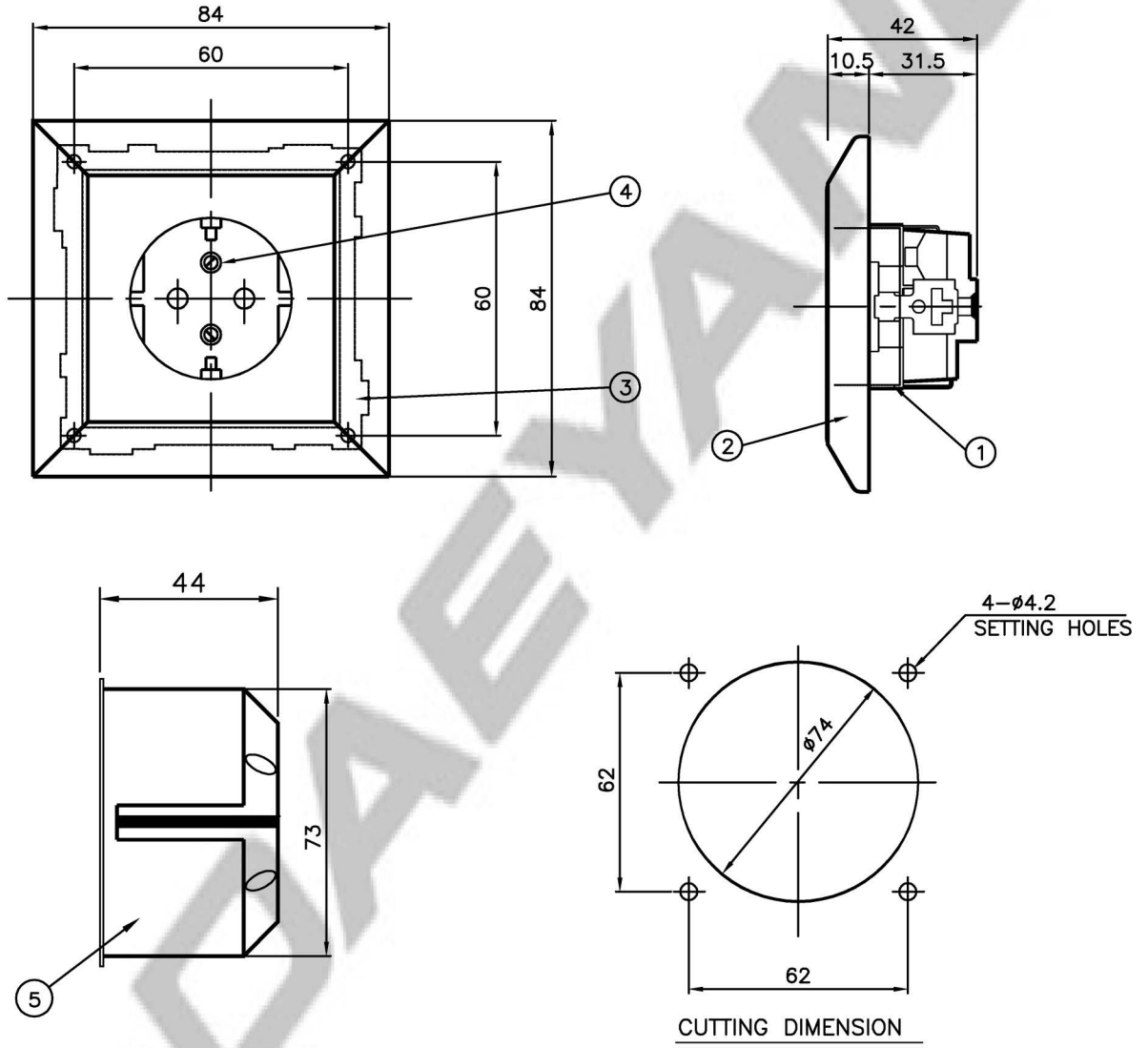

CAPACITY	SYMBOL/ SERIAL NO.	CIRCUIT DIAGRAM
AC 250V		
16A		



5	MOUNTING BOX		1	B15	3	MOUNTING PLATE	STEEL	1	
4	SCREW	STEEL	1		2	COVER	ABS	1	
					1	INTERIOR BODY	PHENOL	1	
NO	NAME OF PARTS	MATERIAL	Q'TY	REMARKS	NO	NAME OF PARTS	MATERIAL	Q'TY	REMARKS

APPROVED	B. K. KIM	UNIT	MM	TITLE; NON WATERTIGHT SINGLE FLUSH RECEPTACLE 2P+1E (DIN TYPE) FOR MARINE USE					
CHECKED	J. W. PARK	SCALE	N/S						
DRAWING	H. S. SHIN	COLOR	POLAR WHITE						
DATE	2016.02.01	IP	20						
				MODEL NO.	S-1014PT(B15)	WEIGHT	0.5 Kg		
				DWG NO.	L62320023	SHEET NO.	131-1		